

Monitoring Report
“Biomass wastes to energy at OJSC “Ilim Group” Branch in the town of Bratsk”

Version 2.1
27 April 2010

Monitoring period: 01.01.2008 – 31.12.2009

Executed by CCGS LLC

CONTENTS

- A. General project activity and monitoring information
- B. Key monitoring activities
- C. Quality assurance and quality control measures
- D. Calculations of GHG reductions

ANNEXES

- Annex 1. The provisions for quality control procedure in relation to preparation of project design documents and monitoring reports for greenhouse gas emission reduction projects at CCGS LLC
- Annex 2. Basic steam supply diagram of OJSC “Ilim Group” Branch in the town of Bratsk.
- Annex 3. List of major heat consumers
- Annex 4. Calculation model (Excel-file)

SECTION A. General Project activity information

A.1. Title of the project activity

"Biomass wastes to energy at OJSC "Ilim Group" Branch in the town of Bratsk".

A.2. Short description of the project activity

The project envisages complex modernization of the energy system of Bratsk Pulp and Paperboard Mill (BPPM) and switching of the boiler equipment to fluidized bed combustion of bark and wood wastes (BWW) and wastewater sludge (WWS).

The project envisages complex modernization of the energy system of BPPM in three stages.

The first stage:

- reconstruction of E-75-40K boiler unit No.16 for BWW combustion without residual fuel oil firing (or any other fossil fuel) for fuel stabilization due to implementation of fluidized bed combustion technology. Design, equipment manufacturing, installation supervision and start-up and commissioning were carried out by LLC "Engineering Energy Company "INEKO". Equipment was mounted by LLC "Energomash - Eastern Siberia"

The second stage:

- reconstruction of E-75-40K boiler unit No.14 for BWW combustion without residual fuel oil firing for fuel stabilization with increase of steam output to 90 t/h due to implementation of fluidized bed combustion technology. Design, equipment manufacturing, installation supervision and start-up and commissioning were carried out by LLC "Engineering Energy Company "INEKO". Equipment was mounted by LLC "Energomash - Eastern Siberia".

The third stage:

- installation of a new E-90-3.9-440DFT boiler unit No.15 designed for fluidized bed combustion of BWW and WWS without residual fuel oil firing for fuel stabilization using "Kvaerner Power" technologies (Finland);
- modernization of BWW feed system of renewed utilizing boilers No.14, No.15 and No.16;
- modernization of the thermal flow diagram of THPP.

All works were performed by "LLC "Energotekhnomash" which is a legal successor of LLC "Energomash - Eastern Siberia".

The required amount of investments into the first stage totaled to EUR 1.6 million. In many respects it was a pilot stage with the objective to study the possibility of applying new BWW combustion technologies and to check them.

The second stage builds on the results and findings of the first stage. Implementation of the second stage required by far more time and investments. The required investments into the second stage totaled to about EUR 4 million.

The required investments into the third stage amount to around EUR 24.6 million.

A.3. Monitoring period

- Monitoring period starting date: 01.01.2008;
- Monitoring period closing date: 31.12.2009.

A.4. Methodology applied to the project activity (incl. version number)**A.4.1. Baseline methodology**

The developer proposes his own approach [R1] to the baseline setting and GHG emission reductions calculation and does not agree it with any methodologies for the clean development mechanism (CDM), but he certainly makes his approach consistent with the requirements of *Decision 9/CMP.1, Appendix B* [R2].

A.4.2. Monitoring methodology

The monitoring plan was developed following our own approach [R1] in accordance with the project specifics and requirements of *Decision 9/CMP.1, Appendix B* [R2] without using any approved CDM methodologies.

A.5. Status of implementation including time table for major project parts

Activity	Date
<u>First stage.</u> Reconstruction of E-75-40K boiler unit No.16	April 2000 – June 2001
<u>Second stage.</u> Reconstruction of E-75-40K boiler unit No.14	April 2002 – July 2004
<u>Third stage.</u> Installation of a new E-90-3.9-440DFT boiler unit No.15. Modernization of BWW feed system. Modernization of the thermal flow diagram of THPP.	<u>June 2007 – 2 quarter 2010</u>

A.6. Intended deviations or revisions to the registered PDD

There are no deviations or revisions to the registered PDD.

A.7. Intended deviations or revisions to the registered monitoring plan

There are no deviations or revisions to the registered monitoring plan.

A.8. Changes since last verification

There are no changes as this is the first monitoring verification.

A.9. Person(s) responsible for the preparation and submission of the monitoring report

The person (s) responsible for the preparation and submission of the monitoring report are:

OJSC "Ilim Group" Branch in Bratsk"

Aleksey Ananin – Director for labour protection, industrial and environmental safety (2008).

Nikolay Sikov - Director for labour protection, industrial and environmental safety (2009).

CCGS LLC

- Vladimir Dyachkov, Director of Project Implementation Department
- Evgeniy Zhuravskiy, Specialist of Project Implementation Department

SECTION B. Key monitoring activities according to the monitoring plan for the monitoring period stated in A.3**B.1. Monitoring equipment types**

The measuring devices have been provided in accordance with the official rules “Electricity Metering Rules”, “Heat Metering Rules” etc. The devices have undergone regular inspection and supervision under the Federal Law “On Uniformity of Measurements”. Table B.1.1. shows metrological performance of the measuring devices used for monitoring.

Table B.1.1. Data on metering devices for GHG emission reduction monitoring

Metered parameter	Mark and type of meter		Serial number	Measure ment range	Unit	Error, accuracy class	Calibration interval (month)	Last calibration data	Organisation which performs calibration
Mass consumption of residual fuel oil in boiler No.9 under the project during the year y	Flow meter (Supply line)	Metran-43DD	60023	0.1	kgf/cm ²	0.5	24	15.09.2008	LLC “Avtomatika-Servis”
	Flow meter (Return line)	Metran-43DD	60022	0.1	kgf/cm ²	0.5	24	15.09.2008	LLC “Avtomatika-Servis”
Mass consumption of residual fuel oil in boiler No.14 under the project during the year y	Flow meter (Supply line)	M-Point/PROCO M11ZL	R1230795/230795	10	m ³ /h	1	24	15.12.2007	LLC “Avtomatika-Servis”
	Flow meter (Return line)	Micro Motion F100S-131SBFZHZZ ZZ	532382 / M.3704516	8	m ³ /h	1	24	15.05.2008	LLC “Avtomatika-Servis”

Mass consumption of residual fuel oil in boiler No.16 under the project during the year y	Flow meter (Supply line)	M-Point/PROCO M11ZL	R1230795 / 230795	10	m ³ /h	1	24	15.08.2009	LLC "Avtomatika-Servis"
	Flow meter (Return line)	Metran-43DD	60022	0.1	kgf/cm ²	0.5	24	15.09.2008	LLC "Avtomatika-Servis"
Calorific value of residual fuel oil over the year y	Calorimetric bomb	V-08-MA	060	-	J/kg	0.10%	12	20.02.2009	LLC " Predpriyatie Avtomatizatsii"
	Weighs	VR-2218	306030678	0-220	g	high	12	15.06.2009	LLC "Predpriyatie Avtomatizatsii"
	Set of weighs	G-2-210	955	1-210	g	F1	12	15.09.2009	LLC " Predpriyatie Avtomatizatsii"
Heat generation by boiler No.9 under the project during the year y	Flow meter	EH-61007	25904	1	kgf/cm ²	0.5	24	15.06.2009	LLC "Avtomatika-Servis"
	Pressure meter	Metran-43DI	L5467	0-60	kgf/cm ²	0.5	24	15.04.2009	LLC "Avtomatika-Servis"
		KSU-1	600102	0-60	kgf/cm ²	1.5	12	14.01.2010	LLC "Avtomatika-Servis"
	Temperature gage	THK, KSP-1	805003	0-600	°C	1.5	12	15.08.2009	LLC "Avtomatika-Servis"
Heat generation by boiler No.14 under the project during the year y	Flow meter	Metran-22-DD-2450	5932	250	kPa	0.5	36	15.05.2009	LLC "Avtomatika-Servis"
	Pressure meter	Metran-22DI	5716	0-60	kgf/cm ²	0.5	24	15.04.2009	LLC "Avtomatika-Servis"
	Temperature gage	THA, IPM0399/M3	12-1437	0-1000	°C	0.5	24	17.11.2009	LLC "Avtomatika-Servis"

Heat generation by boiler No.16 under the project during the year y	Flow meter	Metran-100DD	823386	250	kPa	0.5	36	12.11.2008	LLC "Avtomatika-Servis"
	Pressure meter	Sapfir-22DI	502141	0-60	kgf/cm ²	0.5	24	15.10.2008	LLC "Avtomatika-Servis"
	Temperature gage	THA, IPM0399/M2	11-5139	0-1000	°C	0.5	24	23.12.2008	LLC "Avtomatika-Servis"
Heat generation by boiler No.11 under the project during the year y	Flow meter	Diff -El	850589	1.53	kgf/cm ²	0.5	24	15.05.2008	LLC "Avtomatika-Servis"
	Pressure meter	Press-El	800837	0-50	kgf/cm ²	0.5	24	15.06.2008	LLC "Avtomatika-Servis"
	Temperature gage	thermocouple NiCr-Ni	-	0-500	°C	-	-	Calibration is not required	
Heat generation by boiler No.12 under the project during the year y	Flow meter	Diff-El	652510	1.53	kgf/cm ²	0.5	24	15.05.2008	LLC "Avtomatika-Servis"
	Pressure meter	Press-El	601055	0-50	kgf/cm ²	0.5	24	15.05.2009	LLC "Avtomatika-Servis"
	Temperature gage	thermocouple NiCr-Ni	-	0-500	°C	-	-	Calibration is not required	
Total heat supply (in the form of steam) to end-users from THPP and CHPP-6 during the year y	Flow meter	Metran-100DD	153081	0.4	kgf/cm ²	0.5	36	15.04.2010	LLC "Avtomatika-Servis"
	Pressure meter	Metran-43DI	JI6697	0-25	kgf/cm ²	0.5	24	15.04.2010	LLC "Avtomatika-Servis"
	Temperature gage	THK, KSP-1	803622	0-400	°C	0.05/1.5	12	15.09.2009	LLC "Avtomatika-Servis"
Heat supply (in the form of steam) to	Flow meter	Metran-43DD	153086	0.63	kgf/cm ²	0.5	36	15.05.2007	LLC "Avtomatika-Servis"

end-users from CHPP-6 under the project during the year y	Pressure meter	Sapfir-22DI	156845	0-25	kgf/cm ²	0.5	24	15.03.2009	LLC "Avtomatika-Servis"
Electricity generation at CHPP-2 under the project during the year y	Electric meter	SAZU I 670m	909998	-	kW*h	2	48	15.03.2007	LLC "Avtomatika-Servis"
Electricity consumption for auxiliary needs of CHPP-2 under the project during the year y	Electric meter	SAZU I 670m	707874	-	kW*h	2	48	15.03.2007	LLC "Avtomatika-Servis"
Electricity consumption for auxiliary needs of boiler house under the project during the year y	Electric meter	SAZU I 670m	575043	-	kW*h	2	48	I quarter 2008	LLC "Avtomatika-Servis"

The data for the device measuring WWS moisture content are not available because WWS will be fired in Boiler No.15, whose installation will be completed in 2010.

B.2. Monitored data

The data has been monitored in accordance with the schemes shown in Fig. B.2.1.

Table B.2.1. Data collected in order to monitor emissions from the project, and how this data is archived

ID number	Data variable	Source of data	Data unit	Measured (m), calculated (c), estimated (e)	Recording frequency	Proportion of data to be monitored	How is the data archived? (electronic/ paper)	Numerical value	
								2008	2009
1. $FC_{RFO,9,PJ,y}^m$	Mass residual fuel oil consumption in boiler No.9 under the project during the year y	The Mill's energy service	t	m	Continuously	100 %	Electronic and paper	3 723	1 858
2. $FC_{RFO,14,PJ,y}^m$	Mass residual fuel oil consumption in boiler No.14 under the project during the year y	The Mill's energy service	t	m	Continuously	100 %	Electronic and paper	3 674	4 538
3. $FC_{RFO,15,PJ,y}^m$	Mass residual fuel oil consumption in boiler No.15 under the project during the year y	The Mill's energy service	t	m	Continuously	100 %	Electronic and paper	0*	0*
4. $FC_{RFO,16,PJ,y}^m$	Mass residual fuel oil consumption in boiler No.16 under the project during the year y	The Mill's energy service	t	m	Continuously	100 %	Electronic and paper	3 784	4 388
5. $NCV_{RFO,y}$	Average net calorific value of residual fuel oil in the year y	The Mill's energy service	GJ/t	m	Once per week	100 %	Electronic and paper	40,09	39,56

Table B.2.2. Data collected in order to monitor emissions from the baseline, and how this data is archived

ID number	Data variable	Source of data	Data unit	Measured (m), calculated (c), estimated (e)	Recording frequency	Proportion of data to be monitored	How is the data archived? (electronic/ paper)	Numerical value	
								2008	2009
6. $HG_{9,PJ,y}$	Heat generation by boiler No.9 under the project during the year y	The Mill's energy service	GJ	m, c	Continuously	100 %	Electronic and paper	1 090 249	985 423
7. $HG_{14,PJ,y}$	Heat generation by boiler No.14 under the project during the year y	The Mill's energy service	GJ	m, c	Continuously	100 %	Electronic and paper	1 571 745	1 364 133
8. $HG_{15,PJ,y}$	Heat generation by boiler No.15 under the project during the year y	The Mill's energy service	GJ	m, c	Continuously	100 %	Electronic and paper	0*	0*
9. $HG_{16,PJ,y}$	Heat generation by boiler No.16 under the project during the year y	The Mill's energy service	GJ	m, c	Continuously	100 %	Electronic and paper	1 232 933	1 229 613
10. HS_y^{total}	Total heat supply (in the form of steam) to end-users from THPP and CHPP-6 during the year y	The Mill's energy service	GJ	m, c	Continuously	100 %	Electronic and paper	18 795 581	18 070 221
11. $HS_{CHPP6,PJ,y}$	Heat supply (in the form of steam) to end-users from CHPP-6 under the project during the year y	The Mill's energy service	GJ	m, c	Continuously	100 %	Electronic and paper	9 255 292	8 657 351
12. $HG_{11,y}$	Heat generation by boiler No.11 during the year y	The Mill's energy service	GJ	m, c	Continuously	100 %	Electronic and paper	4 873 471	5 153 933
13. $HG_{12,y}$	Heat generation by boiler No.12 during the year y	The Mill's energy service	GJ	m, c	Continuously	100 %	Electronic and paper	5 321 577	5 409 039
14. $EG_{CHPP2,PJ,y}$	Electricity generation at CHPP-2 under the project during the year y	The Mill's energy service	MWh	m	Continuously	100 %	Electronic and paper	42 284	41 024
15. $EC_{CHPP2,PJ,y}$	Electricity consumption for auxiliary needs of CHPP-2 under the project during the year y	The Mill's energy service	MWh	m	Continuously	100 %	Electronic and paper	17 289	16 928

16. $EC_{BH,PJ,y}$	Electricity consumption for auxiliary needs of the boiler house under the project during the year y	The Mill's energy service	MWh	m	Continuously	100 %	Electronic and paper	23 821	22 985
17. $FC_{BWW,9,PJ,y}^m$	Mass BWW consumption in boiler No.9 under the project during the year x	The Mill's energy service	t	c	Continuously	100 %	Electronic and paper	178 652	161 879
18. $FC_{BWW,14,PJ,y}^m$	Mass BWW consumption in boiler No.14 under the project during the year x	The Mill's energy service	t	c	Continuously	100 %	Electronic and paper	261 493	213 459
19. $FC_{BWW,15,PJ,y}^m$	Mass BWW consumption in boiler No.15 under the project during the year x	The Mill's energy service	t	c	Continuously	100 %	Electronic and paper	0*	0*
20. $FC_{BWW,16,PJ,y}^m$	Mass BWW consumption in boiler No.16 under the project during the year x	The Mill's energy service	t	c	Continuously	100 %	Electronic and paper	189 079	199 774
21. $BWW_{side,PJ,y}^m$	Quantity of BWW supplied to BPPM (for combustion) from outside companies under the project during the year x	The Mill's energy service	t	m	As BWW is supplied	100 %	Electronic and paper	96 223	113 203
22. $FC_{WWS,BH,PJ,y}^m$	Mass WWS consumption in the boiler house under the project during the year x	The Mill's energy service	t	m	With each batch of WWS	100 %	Electronic and paper	0*	0*
23. $W_{WWS,PJ,y}$	Average moisture content of WWS under the project in the year x	The Mill's energy service	%	m	Daily	100 %	Electronic and paper	0*	0*

* Installation of Boiler No.15 will be completed in 2010. Therefore, the values of monitoring parameters No.3, 8, 19, 22 and 23 in Table B.2.2 are equal to zero. All numerical values of monitored parameters given in the monitoring report have been checked and are supported by documents. The documents where these values are recorded are available at the enterprise.

B.3. The environmental service

The enterprise has an environmental control and management department. The work of the department is guided by the current law, orders and decrees of the general director, and instructions of the state environmental control service, the committee for natural resources of the Irkutsk Region. The department employs qualified staff and is able to ensure proper industrial environmental monitoring under the project.

The department is responsible for monitoring of:

- emission of pollutants into the atmosphere;
- wastewater quality;
- utilization, stockpiling, transportation and disposal of industrial wastes.

During the project implementation the analytical monitoring of various environmental impacts has been carried out in accordance with the existing rules and schedule. The data obtained by the analytical laboratory has been processed and summarized in monthly and annual reports which contain all required detailed information including data by production sites covered by this project.

B.4. Data processing and archiving (incl. software used)

All data will be stored in the Mill’s archive in electronic and paper form for at least 2 years after the end of the crediting period or the last issue of ERUs.

SECTION C. Quality assurance and quality control measures**C.1. Quality control (QC) and quality assurance (QA) procedures undertaken for data monitored****Table C.1.1. Quality control (QC) and quality assurance (QA) procedures undertaken for data monitored**

Data (Indicate table and ID number)	Uncertainty level of data (high/medium/low)	Explain QA/QC procedures planned for these data
Table B.2.1. ID 1-4	low	Residual fuel oil flow meters are regularly calibrated. Readings of the flow meters are cross-checked with readings of level gages in the residual fuel oil storage tank.
Table B.2.1. ID 5	low	Laboratory equipment is regularly calibrated. Results of laboratory analysis are cross-checked with the fuel supplier’s certificates.
Table B.2.2. ID 6-13	low	Heat meters are regularly calibrated; readings are cross-checked with balance data.
Table B.2.2. ID 14-16	low	Electricity meters are regularly calibrated.
Table B.2.2. ID 17-20	low	The algorithm for calculation of BWW consumption is constantly updated based on boiler performance data.
Table B.2.2. ID 21	low	The BWW transportation vehicles undergo control weighing every six months. Arrival of each vehicle is recorded in an operating log at the handling and metering point. If any doubts arise as to the compliance of the vehicle loading with the data indicated in the transportation documents (waybills, bills of landing, contracts and delivery certificates for BWW), the personnel of the handling and metering point take check measurement of the BWW volume in this vehicle.
Table B.2.2. ID 22	low	The WWS transportation vehicles undergo control weighing every six months. Arrival of each vehicle is recorded in an operating log at the handling and metering point. If any doubts arise as to the compliance of the vehicle loading with the data indicated in the transportation documents, the personnel of the handling and metering point take check measurement of the WWS volume in this vehicle.
Table B.2.2. ID 23	low	Laboratory equipment is regularly calibrated.

Internal check-out

The responsibility for timely and full collection of primary data, organization of internal check-out of monitoring reports and for dealing with other organizational issues related to monitoring lies with the following persons:

- The Director for labour protection, industrial and environmental safety A. Ananin (2008)
- The Director for Labour Protection, Industrial and Environment Safety, N. Sikov (2009).

The responsibility for collection, check-out and transfer of primary data for monitoring lies with the following persons:

- The Head of CHPP N. Gradanovich
- The Lead Engineer of the Chief Power Engineer Department, I. Andreev.

The responsibility of these persons is specified in Order No FB/524 of 29 .12. 2007 and № FB 1028 of 24 .11. 2009.

Cross-check

Check of the monitoring report is carried out by the Director of the Project Implementation Department of CCGS LLC, or, on his instructions, by other Specialist of the Project Implementation Department who was not directly involved in preparation of this project monitoring report.

Additional cross check is carried out by the director of the Project Development Department of CCGS LLC, or, on his instructions, by other specialist of the Project Development Department.

At CCGS LLC the procedure for verification of the monitoring reports are laid down in “Regulations on quality check and control of GHG emission reduction project design documents (PDD) and monitoring reports at CCGS LLC” (see Annex 1).

C.2 Operational and administrative structure

C.2.1. Monitoring procedures

Data transfer

Original request for primary GHG emission reductions monitoring data is made by the Director of the Project Implementation Department of CCGS LLC to the Central Office of “Ilim Group” in St.-Petersburg, namely to the Director for Labour Protection, Fire Safety and Environment, who in his turn gives instructions to a certain enterprise to collect the requested data. Each enterprise that is implementing projects within the framework of the Kyoto Protocol has specific persons (a working group) that responsible for collection, control and transfer of monitoring data. The responsibility of these persons is specified in corresponding orders. At “Ilim” Group Branch in Bratsk the responsibility of such persons are set forth in Order No FB/524 of 29 .12. 2007 and No FB/1028 of 24 .11.2009.

The information collected at the enterprise is transferred to the Central Office, namely to the Director for Labour Protection, Fire Safety and Environment, who in his turn transfers it to the Director of the Project Implementation Department of CCGS LLC (see fig. C.2.1). All information is transferred by e-mail.

On the basis of the received data the Department of Project Implementation of CCGS LLC prepares a GHG emission reduction monitoring report and submits it for additional cross-check to the Project Development Department of CCGS LLC. As soon as all comments made by the Project Development Department are incorporated or resolved the monitoring report is submitted for verification to the enterprise where the project is implemented. At CCGS LLC the procedure for verification of the monitoring reports are laid down in “Regulations on quality check and control of GHG emission reduction project design documents (PDD) and monitoring reports at CCGS LLC” (see Annex 1).

After the report is verified and amended as necessary, the Director of the Project Implementation Department of CCGS LLC informs the Director for Labour Protection, Fire Safety and Environment of “Ilim” Group’s Central Office in St.-Petersburg about preliminary monitoring results and, if there are no comments on his part, the General Director of CCGS LLC takes the final decision to submit the monitoring report for verification to an independent expert organization.

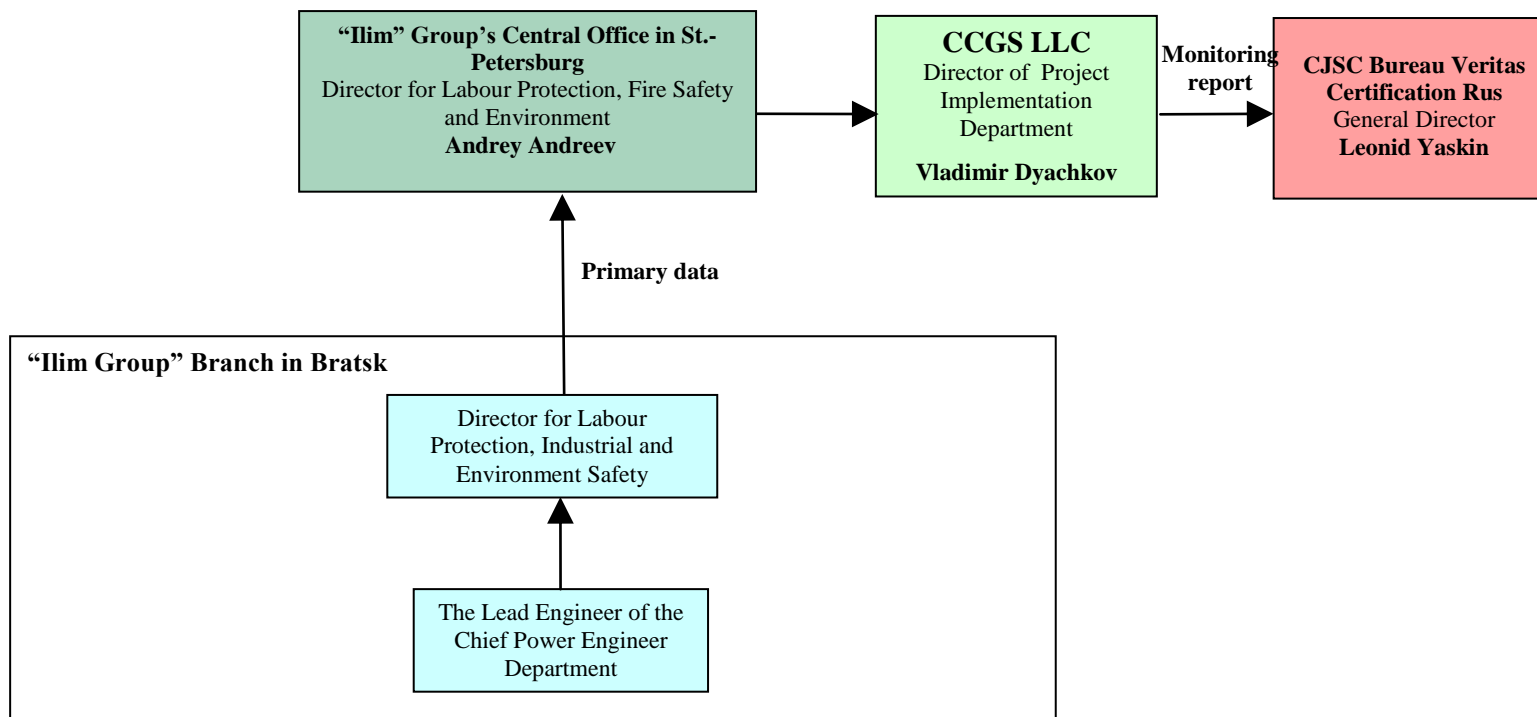

Fig. C.2.1. Data transfer scheme (from primary data to monitoring report)

Collection and record of data

Collection and record of data required for calculation of GHG emission reductions have been carried out in accordance with the metering points scheme shown in Fig B.2.1.

The project envisages reconstruction of the boiler house with installation of a central boiler control panel and connection of the boilers to the automatic process control system of the Mill. APCS of the Mill ensures automated primary data collection and processing. Readings of heat and electricity meters and residual fuel oil flow meters have been transferred to the control units for further processing and archiving.

1. Mass residual fuel oil consumption in the utilizing boilers under the project during the year y has been determined based on readings of residual fuel oil flow meters. Readings of flow meters are cross-checked with readings of level gages in the residual fuel oil storage tank. Mass residual fuel oil consumption in boilers No.9, No.14, No.15 and No.16 under the project during the year y (ID 1-4) has been determined based on readings of the residual fuel oil meters, installed at the forward and return residual fuel oil feeding lines of the boilers.
2. The analysis of net calorific value of residual fuel oil has been conducted on a weekly basis by THPP laboratory. The results of the laboratory analysis have been cross-checked with the fuel suppliers' certificates. Average net calorific value of residual fuel oil in the year y (ID 5) has been determined as an average value at the end of the year y.
3. Heat generation by THPP boilers under the project during the year y (ID 6-9, 12-13) has been determined based on reading of the heat meters installed at each boiler. Heat generation data have been regularly transferred to control units and archived.
4. Total heat supply (in the form of steam) to end-users from THPP and CHPP-6 during the year y (ID 10) and heat supply (in the form of steam) to end-users from CHPP-6 under the project during the year y (ID 11) have been determined on the basis of readings of heat meters installed at THPP, CHPP-6, and on the demand side. The list of major heat consumers is given in Annex 3, the basic steam supply diagram of OJSC “Ilim Group” Branch in the town of Bratsk is given in Annex 2. Heat supply data has been collected on a weekly basis and archived.
5. Electricity generation at CHPP-2 under the project during the year y (ID 14) and electricity consumption for auxiliary needs of CHPP-2 under the project during the year y (ID 15) have been determined on the basis of readings of electricity meters installed at CHPP-2. Electricity generation data and data on electricity consumption for auxiliary needs of CHPP-2 have been regularly transferred to the control unit and archived.
6. Electricity consumption for auxiliary needs of the boiler house under the project during the year y (ID 16) has been determined on the basis of readings of electricity meters installed in the boiler house. Data on electricity consumption for auxiliary needs of the boiler house has been regularly transferred to the control unit and archived.
7. Mass BWW consumption in boiler No.9 under the project during the year x (ID 17) has been determined using the calculating algorithm. Mass BWW consumption in boilers No.14, No.15 and No.16 under the project during the year x (ID 18-20) has been determined by the automation system as per the preset algorithm. BWW combustion data has been regularly transferred to the control unit and archived.
8. The quantity of BWW supplied (for combustion) from outside companies has been determined at the special handling and metering point based on the number of vehicles passing through it. Data on the quantity of supplied BWW has been cross-checked with waybills, bills of landing, contracts and

delivery certificates. The quantity of BWW supplied to BPPM (for combustion) from outside companies under the project during the year x (ID 21) has been determined as a sum of mass BWW quantities supplied during the year x .

9. Mass WWS consumption in the boiler house under the project during the year x (ID 22) has been determined at the special handling and metering point based on the number of vehicles passing through it.
10. The analysis of WWS has been conducted on a daily basis by THPP laboratory. Average moisture content of WWS under the project in the year x (ID 23) has been determined as an average value at the end of the year x .

The data sources for calculation of GHG emission reductions in the course of the monitoring during the year have been: internal data of THPP, statistical report form No.6-TP “Thermal power plant performance data”, “Report on heat utilization by product type”, “Wood wastes generation and utilization balance of Bratsk industrial site”.

Data storage

The maintenance personnel of THPP and chips production are responsible for daily data collection and archiving according to the internal rules and regulations.

Every day shift fitters of instrumentation and automation department (of CHPP-2, CHPP-3 and the boiler house) printed out readings of daily heat generation meters, heat supply meters and fuel flow meters recorded in the APCS and submitted these data to the production and technical department (PTD). Shift electricians (of CHPP-2 and the boiler house) took readings of electricity meters and entered those into the logs. The logs have been submitted to the PTD.

Specialists of THPP laboratory entered into reports the results of the analysis of residual fuel oil NCV (every week) and WWS moisture content (every day). The reports have been submitted to the PTD.

Specialists of the chips production have kept daily operating logs, in which they recorded on a daily basis the data on quantity of BWW supplied from outside companies, and on quantity of WWS fired in the boiler house. The daily operating logs have been submitted to the PTD.

Energy resources monitoring engineer of the PTD has summarized the provided data (some data was taken from the plant’s overall energy monitoring system APCS), filled in the logs and drawn up reports. The reports have been submitted to the department of the chief energy engineer, accounting department and economics department.

The data to be monitored and required for determination according to parag.37 of Decision 9/CMP.1 will be stored for at least 2 years after the last ERU transfer under the project. The data has been archived in paper and electronic form. The person responsible for data collection and storage is the leading engineer of the PTD.

The sources of primary data are shown in Table C.2.1.

Table C .2.1. The sources of primary data	
Primary data	Document where the parameter is recorded
Mass residual fuel oil consumption in boiler No.9 under the project during the year y	"Reference for combustion of main and backup fuel at THPP"
Mass residual fuel oil consumption in boiler No.14 under the project during the year y	
Mass residual fuel oil consumption in boiler No.15 under the project during the year y	
Mass residual fuel oil consumption in boiler No.16 under the project during the year y	
Mass BWW consumption in boiler No.9 under the project during the year y	
Mass BWW consumption in boiler No.14 under the project during the year y	
Mass BWW consumption in boiler No.15 under the project during the year y	
Mass BWW consumption in boiler No.16 under the project during the year y	
Quantity of BWW supplied to BPPM (for combustion) from outside companies under the project during the year y	"Balance of wood wastes and bark generation and utilization at Bratsk Production Site"
Heat generation by boiler No.9 under the project during the year y	"Annex to the Energy Resources Report"
Heat generation by boiler No.11 under the project during the year y	
Heat generation by boiler No.12 under the project during the year y	
Heat generation by boiler No.14 under the project during the year y	
Heat generation by boiler No.15 under the project during the year y	
Heat generation by boiler No.16 under the project during the year y	
Electricity generation at CHPP-2 under the project during the year y	"Daily Records of Electric Meter Readings 6kV Main Switchgear of CHPP-2"
Electricity consumption for auxiliary needs of CHPP-2 under the project during the year y	"Energy Resources Distribution Report"
Electricity consumption for auxiliary needs of the boiler house under the project during the year y	Form 6-TP
Average net calorific value of residual fuel oil in the year y	Form 6-TP
Heat supply (in the form of steam) to end-users from THPP under the project during the year y	Form 6-TP
Heat supply (in the form of steam) to end-users from CHPP-6 under the project during the year y	" Purchased Heat and Electricity Distribution Report"

Instrumentation calibration

The instrumentation calibration and check-out have been carried out by contracted specialized organizations licensed for this type of activity in accordance with the Federal law “On uniformity of measurements”. The evaluation of potential uncertainties and revision of data have been also carried out by the metrology engineer proceeding from the rated instrumental error of each type of instrumentation.

The required calibration of all instrumentation has been carried out by LLC “Automation Enterprise” in accordance with the schedule developed by the metrology department.

The chief metrologist of OJSC “Ilim Group” Branch in the town of Bratsk is responsible for timely calibration of all instrumentation in accordance with the manufacturer’s requirements.

Troubleshooting procedures

The measuring instruments have been calibrated during scheduled shutdowns of the equipment. If necessary the removed measuring instrument is replaced with a gaged back up instrument. Operation of the equipment without measuring instruments is not allowed.

Shall any instrument fail, the respective parameters are to be monitored with a help of a duplicate instrument or, if such is not available, the failed instrument is to be replaced with a gaged back-up instrument. If the failed instrument cannot be replaced while the equipment is running, then the parameters is monitored for not more than 15 days in one year based on calculation of an average value of this instrument’s readings taken over the three days prior to the failure. This monitoring procedure was developed based on paragraph 9.8 of "The Rules for Heat and Heat Carrier Metering". [R14].

If the equipment is operated without instrument-based monitoring of any parameter for more than 15 days, then the calculations is made using the most conservative (in terms of GHG emission reductions) value from the start of the project monitoring.

In case of any breakdown of the utilizing boilers, heat and electricity generation goes down, whereas heat supply from CHPP-6 and electricity consumption from the power grid increases. If the process of BWB and WWS combustion in the boilers becomes less stable, additional consumption of residual fuel oil increases. Any variation of fuel consumption in the utilizing boilers or reduction of heat and electricity supply as a result of emergency situations is automatically recorded by the meters.

All incidents that take place at the Mill are recorded by the department of the chief energy engineer and by the technical supervision service of the health, environment and safety department in the prescribed order. Information on major incidents are recorded in the monitoring report.

C.2.2. Roles and responsibility

The management of “Ilim” Group’s Central Office in Saint-Petersburg is responsible for monitoring plan observance at the enterprise (director for labour protection, fire safety and environment).

The management of OJSC “Ilim Group” Branch in Bratsk is responsible for:

- normal operation of the equipment;
- timely calibration and proper maintenance of instrumentation (chief metrologist);
- collection of all data required for calculation of GHG emission reductions under the project (director for labour protection, industrial and environment safety);
- arranging and holding training sessions for the Mill’s personnel regarding collection of data required for the GHG emissions monitoring under the project (director for labour protection, industrial and environment safety).

The management of CCGS LLC is responsible for:

- arranging and holding training sessions for the Mill’s personnel regarding collection of data required for the GHG emissions monitoring under the project (director of project implementation department);
- drawing up of the monitoring report (director of project implementation department);
- check of correctness of the primary data and calculations GHG emissions reductions (director of project development department);
- interaction with the independent expert organization concerning verification of GHG emissions reductions (director of project implementation department).

The roles and responsibilities of technicians and engineers of OJSC “Ilim Group” Branch in Bratsk related to collection, check-out and transfer of GHG emission reduction monitoring data are shown in Fig. C.2.1. and Table C.2.1. The authorities of the responsible persons were recorded in the order FB/524 of 29 .12. 2007 and FB/1028 of 24 .11.2009.

C.2.3. Trainings

The THPP personnel whose work was connected with operation of the reconstructed boilers underwent training organized by the equipment manufacturer. All maintenance personnel have the required qualification and valid permits to operate THPP’s main equipment. New employees and personnel who need to confirm their admission group are required to undergo respective training, pass a test and obtain a permission certificate in accordance with the Federal law “On industrial safety of hazardous facilities”. The person responsible for the personnel training is director for labour protection, industrial and environmental safety. His responsibilities include:

1. Receipt of training applications.
2. Drawing up training schedules.
3. Concluding contracts for training and submission to the accounting department for payment.
4. Control over training documents.

Regularly, minimum once a year, specialists of LLC “CCGS” carry out test verification with the purpose of checking out the observance of the monitoring plan at OJSC “Ilim Group” Branch in the town of Bratsk.

Check-out of the equipment required for primary monitoring data collection and personnel training were carried out on 20.10.2008-22.10.2008, 12.03.2009-14.03.2009, 9.06.2009.

C.2.4. Involvement of Third Parties

LLC "Avtomatika-Servis" is the Third Party involved

C.3. Influence estimation on environment

The project helps to reduce coal combustion at CHPP-6. It results in lower emissions of both greenhouse gases and The calculations were made in accordance with RD 34.02.305-98 “The Methodology for Calculation of Gross Pollutant Emissions from TPP Boilers” [R9], issued by VTI.

As a result of the project the coal consumption at CHPP-6 in year 2008 reduces by an average of 44 thousand tonnes. The emissions of sulfur dioxide reduce by 314 t/year, carbon oxide – by 141 t/year, nitrogen oxides (calculated as nitrogen dioxide) – by 146 t/year, and suspended particles – by 265 t/year. The overall reduction of gross pollutant emissions to the atmosphere amounts to 866 t/year.

As a result of the project the coal consumption at CHPP-6 in year 2009 reduces by an average of 20 thousand tonnes. The emissions of sulfur dioxide reduce by 143 t/year, carbon oxide – by 64 t/year, nitrogen oxides (calculated as nitrogen dioxide) – by 58 t/year, and suspended particles – by 120 t/year. The overall reduction of gross pollutant emissions to the atmosphere amounts to 385 t/year.

Table C.3.1. Variation of pollutant emissions at CHPP-6, t/year

Pollutant emissions	Value	
	2008	2009
Suspended particles	-265	-120
Sulfur dioxide (SO ₂)	-314	-143
Nitrogen oxides calculated as nitrogen dioxide (NO ₂)	-146	-58
Carbon oxide (CO)	-141	-64
Total emissions	-866	-385

SECTION D. Calculation of GHG emission reductions

D.1. Calculation of the project GHG emissions

The total project emissions of GHG during the year y, t CO₂e:

$$PE_y = PE_{RFO,y},$$

where $PE_{RFO,y}$ is the project emissions of CO₂ from combustion of residual fuel oil in the utilizing boilers during the year y, t CO₂e;

$$PE_{RFO,y} = FC_{RFO,PJ,y}^m \times NCV_{RFO,y} \times EF_{CO_2,RFO},$$

where $FC_{RFO,PJ,y}^m$ is the mass residual fuel oil consumption in the utilizing boilers under the project during the year y, t;

$$FC_{RFO,PJ,y}^m = FC_{RFO,9,PJ,y}^m + FC_{RFO,14,PJ,y}^m + FC_{RFO,15,PJ,y}^m + FC_{RFO,16,PJ,y}^m,$$

where $FC_{RFO,9,PJ,y}^m$ is the mass residual fuel oil consumption in boiler No.9 under the project during the year y, t;

$FC_{RFO,14,PJ,y}^m$ is the mass residual fuel oil consumption in boiler No.14 under the project during the year y, t;

$FC_{RFO,15,PJ,y}^m$ is the mass residual fuel oil consumption in boiler No.15 under the project during the year y, t;

$FC_{RFO,16,PJ,y}^m$ is the mass residual fuel oil consumption in boiler No.16 under the project during the year y, t.

$NCV_{RFO,y}$ is the average net calorific value of residual fuel oil in the year y, GJ/t;

$EF_{CO_2,RFO}$ is the CO₂ emission factor for residual fuel oil combustion, t CO₂e/GJ. According to 2006 IPCC Guidelines for National Greenhouse Gas Inventories [R6] for the entire project period is assumed as follows: $EF_{CO_2,RFO} = 0.0774$ t CO₂e/GJ.

D.2. Calculation of the baseline GHG emissions

The total baseline emissions of GHG during the year y, t CO₂e:

$$BE_y = BE_{RFO,y} + BE_{lignite,y} + BE_{grid,y} + BE_{BWW,dump,y} + BE_{WWS,dump,y},$$

where $BE_{RFO,y}$ is the baseline emissions of CO₂ from combustion of residual fuel oil in the utilizing boilers during the year y, t CO₂e;

$$BE_{RFO,y} = FC_{RFO,BL,y} \times EF_{CO_2,RFO},$$

where $FC_{RFO,BL,y}$ is the residual fuel oil consumption in the utilizing boilers under the baseline scenario during the year y, GJ;

$$FC_{RFO,BL,y} = FC_{RFO,9,BL,y} + FC_{RFO,10,BL,y} + FC_{RFO,15,BL,y},$$

where $FC_{RFO,9,BL,y}$ is the residual fuel oil consumption in boiler No.9 under the baseline scenario during the year y, GJ,

$$FC_{RFO,9,BL,y} = HG_{9,BL,y} \times SFC_{RFO,9},$$

where $HG_{9,BL,y}$ is the heat generation by boiler No.9 under the baseline scenario during the year y, GJ;

$$HG_{9,BL,y} = \text{MIN}(HG_{PJ,y}; HG_9^{\text{max}}),$$

where $HG_{PJ,y}$ is the heat production by the utilizing boilers under the project during the year y, GJ;

$$HG_{PJ,y} = HG_{9,PJ,y} + HG_{14,PJ,y} + HG_{15,PJ,y} + HG_{16,PJ,y},$$

where $HG_{9,PJ,y}$ is the heat generation by boiler No.9 under the project during the year y, GJ;

$HG_{14,PJ,y}$ is the heat generation by boiler No.14 under the project during the year y, GJ;

$HG_{15,PJ,y}$ is the heat generation by boiler No.15 under the project during the year y, GJ;

$HG_{16,PJ,y}$ is the heat generation by boiler No.16 under the project during the year y, GJ.

HG_9^{\max} is the maximum quantity of heat that can be produced by boiler No.9 during the year, it was assumed:

$$HG_9^{\max} = 1\,125\,026 \text{ GJ [R1, Section B1].}$$

$SFC_{RFO,9}$ is the specific residual fuel oil consumption for generation of 1 GJ of heat in boiler No.9, GJ/GJ, it was assumed:

$$SFC_{RFO,9} = 0.0347 \text{ GJ/GJ [R1, Section B1].}$$

$FC_{RFO,10,BL,y}$ is the residual fuel oil consumption in boiler No.10 under the baseline scenario during the year y, GJ;

$$FC_{RFO,10,BL,y} = HG_{10,BL,y} \times SFC_{RFO,10},$$

where $HG_{10,BL,y}$ is the heat generation by boiler No.10 under the baseline scenario during the year y, GJ;

$$HG_{10,BL,y} = \text{MIN}((HG_{PJ,y} - HG_{9,BL,y}); HG_{10}^{\max}),$$

where HG_{10}^{\max} is the maximum quantity of heat that can be produced by boiler No.10 during the year, GJ, it was assumed:

$$HG_{10}^{\max} = 614\,488 \text{ GJ [R1, Section B1].}$$

$SFC_{RFO,10}$ is the specific residual fuel oil consumption for generation of 1 GJ of heat in boiler No.10, GJ/GJ, it was assumed:

$$SFC_{RFO,10} = 0.3672 \text{ GJ/GJ [R1, Section B1].}$$

$FC_{RFO,15,BL,y}$ is the residual fuel oil consumption in boiler No.15 under the baseline scenario during the year y, GJ;

$$FC_{RFO,15,BL,y} = HG_{15,BL,y} \times SFC_{RFO,15},$$

where $HG_{15,BL,y}$ is the heat generation by boiler No.15 under the baseline scenario during the year y, GJ;

$$HG_{15,BL,y} = \text{MIN} \left((HG_{PJ,y} - HG_{CHPP2,BL,y}); HG_{15}^{\text{max}} \right),$$

where $HG_{CHPP2,BL,y}$ is the heat production by the boilers of CHPP-2 under the baseline scenario during the year y, GJ;

$$HG_{CHPP2,BL,y} = HG_{9,BL,y} + HG_{10,BL,y}.$$

HG_{15}^{max} is the maximum quantity of heat that can be produced by old boiler No.15 during the year, GJ, is assumed:

$$HG_{15}^{\text{max}} = 1\,339\,346 \text{ GJ [R1, Section B1].}$$

$SFC_{RFO,15}$ is the specific residual fuel oil consumption for generation of 1 GJ of heat in boiler No.15, GJ/GJ, it was assumed: $SFC_{RFO,15} = 0.2810 \text{ GJ/GJ [R1, Section B1].}$

$BE_{\text{lignite},y}$ is the baseline emissions of CO₂ from additional combustion of lignite in the boilers of CHPP-6 during the year y, t CO₂e;

$$BE_{\text{lignite},y} = FC_{\text{lignite},BL,y}^{\text{add}} \times EF_{CO_2,\text{lignite}},$$

where $FC_{\text{lignite},BL,y}^{\text{add}}$ is the additional lignite consumption at CHPP-6 under the baseline scenario as compared with the project scenario during the year y, GJ;

$$FC_{\text{lignite},BL,y}^{\text{add}} = \frac{HS_{CHPP6,BL,y}^{\text{add}} \times K_{\text{turbine}}^{\text{heat}}}{\eta_{\text{boiler}} \times (1 - HA_{\text{boiler}}) \times K_{HF}},$$

where $HS_{CHPP6,BL,y}^{\text{add}}$ is the additional heat supply from CHPP-6 to end-users under the baseline scenario as compared with the project scenario during the year y, GJ;

$$HS_{CHPP6,y}^{\text{add}} = HS_{PJ,y} - HS_{BL,y},$$

where $HS_{PJ,y}$ is the heat supply to end-users due to operation of the utilizing boilers under the project during the year y, GJ;

$$HS_{PJ,y} = HG_{PJ,y} \times SHS_{THPP,PJ,y},$$

where $SHS_{THPP,PJ,y}$ is the factor of heat supply from THPP under the project during the year y;

$$SHS_{THPP,PJ,y} = \frac{HS_{THPP,PJ,y}}{HG_{THPP,PJ,y}},$$

where $HS_{THPP,PJ,y}$ is the heat supply to end-users from THPP under the project during the year y, GJ;

$$HS_{THPP,PJ,y} = HS_y^{total} - HS_{CHPP6,PJ,y},$$

where HS_y^{total} is the total heat supply (in the form of steam) to end-users from THPP and CHPP-6 during the year y, GJ;

$HS_{CHPP6,PJ,y}$ is the heat supply (in the form of steam) to end-users from CHPP-6 under the project during the year y, GJ.

$HG_{THPP,PJ,y}$ is the heat production by the boilers of THPP under the project during the year y, GJ;

$$HG_{THPP,PJ,y} = HG_{PJ,y} + HG_{CHPP3,y},$$

where $HG_{CHPP3,y}$ is the heat production by the boilers of CHPP-3 during the year y, GJ;

$$HG_{CHPP3,y} = HG_{11,y} + HG_{12,y},$$

where $HG_{11,y}$ is the heat generation by boiler No.11 during the year y, GJ;

$HG_{12,y}$ is the heat generation by boiler No.12 during the year y, GJ.

$HS_{BL,y}$ is the heat supply to end-users due to operation of the utilizing boilers under the baseline scenario during the year y, GJ;

$$HS_{BL,y} = HG_{BL,y} \times SHS_{THPP,BL},$$

where $HG_{BL,y}$ is the heat production by the utilizing boilers under the baseline scenario during the year y, GJ;

$$HG_{BL,y} = HG_{9,BL,y} + HG_{10,BL,y} + HG_{15,BL,y}.$$

$SHS_{THPP,BL}$ is the factor of heat supply from THPP under the baseline scenario, it was assumed: $SHS_{THPP,BL} =$

0.705[R1, Section B1].

$K_{turbine}^{heat}$ is the factor of variation of live steam flow to the turbine caused by the variation of the process steam extraction. According to energy characteristic of the turbines it was assumed: $K_{turbine}^{heat} = 1.310$ [R1, Section B1];

η_{boiler} is the efficiency factor of CHPP-6 boilers, it was assumed: $\eta_{boiler} = 0.902$ [R10, page 417];

HA_{boiler} the proportion of heat for auxiliary needs of CHPP-6 boilers, it is assumed: $HA_{boiler} = 0.0233$ [R11, table 3];

K_{HF} is the heat flow factor at CHPP-6, it is assumed: $K_{HF} = 0.98$ [R12, page 135, fig. 10.2].

$EF_{CO_2, lignite}$ is the CO₂ emission factor for lignite combustion, t CO₂e/GJ. According to 2006 IPCC Guidelines for National Greenhouse Gas Inventories [R6] for the entire project period it was assumed: $EF_{CO_2, lignite} = 0.101$ t CO₂e /GJ.

$BE_{grid,y}$ is the baseline emissions of CO₂ from additional electricity consumption from the external power grid during the year y, t CO₂e;

$$BE_{grid,y} = EC_{grid,BL,y}^{add} \times EF_{CO_2,grid,y},$$

where $EC_{grid,BL,y}^{add}$ is the additional electricity consumption from the external power grid under the baseline scenario as compared with the project scenario during the year y, MWh;

$$EC_{grid,BL,y}^{add} = ES_{PJ,y} - ES_{BL,y} - ES_{CHPP6,BL,y}^{add},$$

where $ES_{PJ,y}$ is the electricity supply due to operation of the utilizing boilers under the project during the year y, MWh;

$$ES_{PJ,y} = ES_{CHPP2,PJ,y} - EC_{BH,PJ,y},$$

where $ES_{CHPP2,PJ,y}$ is the electricity supply from CHPP-2 under the project during the year y, MWh;

$$ES_{CHPP2,PJ,y} = EG_{CHPP2,PJ,y} - EC_{CHPP2,PJ,y},$$

where $EG_{CHPP2,PJ,y}$ is the electricity generation at CHPP-2 under the project during the year y, MWh;

$EC_{CHPP2,PJ,y}$ is the electricity consumption for auxiliary needs of CHPP-2 under the project during the year y, MWh.

$EC_{BH,PJ,y}$ is the electricity consumption for auxiliary needs of the boiler house under the project during the year y , MWh.

$ES_{BL,y}$ is the electricity supply due to operation of the utilizing boilers under the baseline scenario during the year y , MWh;

$$ES_{BL,y} = ES_{CHPP2,BL,y} - EC_{BH,BL,y},$$

where $ES_{CHPP2,BL,y}$ is the electricity supply from CHPP-2 under the baseline scenario during the year y , MWh;

$$ES_{CHPP2,BL,y} = EG_{CHPP2,BL,y} - EC_{CHPP2,BL,y},$$

where $EG_{CHPP2,BL,y}$ is the electricity generation at CHPP-2 under the baseline scenario during the year y , MWh;

$$EG_{CHPP2,BL,y} = HG_{CHPP2,BL,y} \times \chi_{CHPP2,BL},$$

where $\chi_{CHPP2,BL}$ is the factor of heat-production-based electricity generation at CHPP-2 under the baseline scenario, MWh/GJ, it is assumed: $\chi_{CHPP2,BL} = 0.0372$ MWh/GJ [R1, Section B1].

$EC_{CHPP2,BL,y}$ is the electricity consumption for auxiliary needs of CHPP-2 under the baseline scenario during the year y , MWh;

$$EC_{CHPP2,BL,y} = HG_{CHPP2,BL,y} \times SEC_{HG,CHPP2,BL},$$

where $SEC_{HG,CHPP2,BL}$ is the specific electricity consumption for production of 1 GJ of heat at CHPP-2 under the baseline scenario, MWh/GJ, it is assumed: $SEC_{HG,CHPP2,BL} = 0.0141$ MWh/GJ [R1, Section B1].

$EC_{BH,BL,y}$ is the electricity consumption for auxiliary needs of the boiler house under the baseline scenario during the year y , MWh;

$$EC_{BH,BL,y} = HG_{BH,BL,y} \times SEC_{HG,BH,BL},$$

where $HG_{BH,BL,y}$ is the heat production by boilers of the boiler house under the baseline scenario during the year y , GJ;

$$HG_{BH,BL,y} = HG_{15,BL,y}.$$

$SEC_{HG,BH,BL}$ is the specific electricity consumption for production of 1 GJ of heat in the boiler house under the baseline scenario, MWh/GJ, it is assumed: $SEC_{HG,BH,BL} = 0.007$ MWh/GJ [R1, Section B1].

$ES_{CHPP6,BL,y}^{add}$ is the additional heat-production-based electricity supply from CHPP-6 under the baseline scenario as compared with the project scenario during the year y , MWh;

$$ES_{CHPP6,BL,y}^{add} = \frac{HS_{CHPP6,BL,y}^{add} \times K_{turbine}^{electricity} \times (1 - SEC_{auxiliary,CHPP6})}{3.6},$$

where $K_{turbine}^{electricity}$ is the factor of variation of electricity generation by the turbine caused by the variation of the process steam extraction. In accordance with the energy characteristic of the turbine it was assumed: $K_{turbine}^{electricity} = 0.305$ [R13, page 95, table 4.6];

$SEC_{auxiliary,CHPP6}$ is the specific electricity consumption for auxiliary needs of CHPP-6, it is assumed: $SEC_{auxiliary,CHPP6} = 0.04$ [R12, page 18].

$EF_{CO_2,grid,y}$ is the CO₂ emission factor for electricity consumed from the external power grid during the year 2008, t CO₂e/MWh. According to Guidelines for Project Design Documents of Joint Implementation Projects [R7, page 43] the CO₂ emission factors for electricity consumed from the power grid in Russia depending on the year are assumed equal to: $EF_{CO_2,grid,y}^{2008} = 0.565$ t CO₂e/MWh, $EF_{CO_2,grid,y}^{2009} = 0,557$ t CO₂e/MWh.

$BE_{BWW,dump,y}$ is the baseline emissions of CH₄ from decomposition of an additional quantity of BWW at the dump during the year y , t CO₂e;

The numerical value of $BE_{BWW,dump,y}$ is determined using the model “Calculation of CO₂-equivalent emission reductions from biomass prevented from stockpiling or taken from stockpiles” developed by “BTG biomass technology group B.V.” based on [R8].

$$BE_{BWW,dump,y} = \left(1 - w_{lignin,BWW}\right) \times k_{BWW} \times \frac{C_{BWW}^{db}}{100} \times \left(1 - \frac{W_{BWW}}{100}\right) \times a \times \zeta \times \left(1 - \frac{\varphi}{100}\right) \times (1 - \zeta_{ox}) \times \frac{V_m}{100} \times \rho_{CH_4} \times GWP_{CH_4} \times$$

$$\times \sum_{x=2001}^{x=y} \left(BWW_{dump,BL,x}^{m,add} \times e^{-k_{BWW}(y-x)} \right)$$

where $BWW_{dump,BL,x}^{m,add}$ is the additional disposal of BWW at the dump under the baseline scenario as compared with the project scenario (amount of fresh biomass utilized) during the year x , t;

$$BWW_{dump,BL,x}^{m,add} = MAX \left(0; FC_{BWW,PJ,x}^m - FC_{BWW,BL}^{m,max} - BWW_{side,PJ,x}^m \right),$$

where $FC_{BWW,PJ,x}^m$ is the mass BWW consumption in the utilizing boilers under the project during the year x , t;

$$FC_{BWW,PJ,x}^m = FC_{BWW,9,PJ,x}^m + FC_{BWW,14,PJ,x}^m + FC_{BWW,15,PJ,x}^m + FC_{BWW,16,PJ,x}^m,$$

where $FC_{BWW,9,PJ,x}^m$ is the mass BWW consumption in boiler No.9 under the project during the year x , t;

$FC_{BWW,14,PJ,x}^m$ is the mass BWW consumption in boiler No.14 under the project during the year x , t;

$FC_{BWW,15,PJ,x}^m$ is the mass BWW consumption in boiler No.15 under the project during the year x , t;

$FC_{BWW,16,PJ,x}^m$ is the mass BWW consumption in boiler No.16 under the project during the year x , t.

$FC_{BWW,BL}^{m,max}$ is the maximum quantity of BWW that can be fired in the utilizing boilers under the baseline scenario during the year, t;

$$FC_{BWW,BL}^{m,max} = FC_{BWW,9}^{m,max} + FC_{BWW,10}^{m,max} + FC_{BWW,15}^{m,max},$$

where $FC_{BWW,9}^{m,max}$ is the maximum quantity of BWW that can be fired in boiler No.9 during the year, t, it is assumed: $FC_{BWW,9}^{m,max} = 189\ 830$ t [R1, Section B1];

$FC_{BWW,10}^{m,max}$ is the maximum quantity of BWW that can be fired in boiler No.10 during the year, t, it is assumed: $FC_{BWW,10}^{m,max} = 60\ 003$ t [R1, Section B1];

$FC_{BWW,15}^{m,max}$ is the maximum quantity of BWW that can be fired in boiler No.15 during the year, t, it is assumed: $FC_{BWW,15}^{m,max} = 130\ 230$ t [R1, Section B1].

$BWW_{side,PJ,y}^m$ is the quantity of BWW supplied to BPPM (for combustion) from the outside companies under the project during the year x , t.

$w_{lignin,BWW}$ is the lignin fraction of C for BWW, it is assumed: $w_{lignin,BWW} = 0.25$ [R8, page 43];

k_{BWW} is the decomposition rate constant for BWW, year⁻¹, it is assumed: $k_{BWW} = \ln(1/2)/15 = 0.046 \text{ year}^{-1}$ [R8, page 42];

C_{BWW}^{db} is the organic carbon content in BWW on dry basis, %, it is assumed: $C_{BWW}^{db} = 50\%$ [R8, page 45];

W_{BWW} is the moisture content of BWW, %, it is assumed: $W_{BWW} = 60\%$ [R8, page 16];

a is the conversion factor from kg carbon to landfill gas quantity, m³/kg carbon, it is assumed: $a = 1.87 \text{ m}^3/\text{kg carbon}$ [R8, page 24];

ζ is the generation factor, it is assumed: $\zeta = 0.77$ [R8, page 41];

φ is the percentage of the stockpile under aerobic conditions, %, it is assumed: $\varphi = 10\%$ [R8, page 80];

ζ_{OX} is the methane oxidation factor, it is assumed: $\zeta_{OX} = 0.10$ [R8, page 43];

V_m is the methane concentration biogas, %, it is assumed: $V_m = 60\%$ [R8, page 41];

ρ_{CH_4} is the density of methane, kg/m³, it is assumed: $\rho_{CH_4} = 0.714 \text{ kg/m}^3$ [R1, Section E4];

GWP_{CH_4} is the global warming potential of methane, t CO₂e/t CH₄, it is assumed: $GWP_{CH_4} = 21 \text{ t CO}_2\text{e/t CH}_4$ [R8, page 12];

y is the year for which to calculate the CO₂-equivalent reduction, year;

x is the year in which fresh biomass is utilized instead of stockpiled, year.

It should be noted that calculation of methane emissions for each year y uses additional BWW stockpiling data from 2001 onwards. Additional BWW stockpiling data for 2001-2007 were determined as of the date of baseline setting. These data was used for calculation of the baseline emissions of CH₄ from decomposition of an additional quantity of BWW at the dump during the year y . Mass BWW consumptions in the boilers were determined using a calculation algorithm. The uncertainty of calculations of additional BWW disposal at the dump in 2001-2007 is close to zero, as for the sake of conservatism maximum values of mass BWW consumption in 2001-2007 were used to determine mass consumption of BWW in boilers No.9, 10 and 15 under the baseline scenario.

Numerical values of BWW mass consumption in boilers No.No.9, 14, 15 and 16 from 2001 till 2007 are given in Table D.2.1.

Table D.2.1. Mass consumption of BWW in boilers No.No.9, 14, 15 and 16 from 2001 till 2007

Parameter	Unit	2001	2002	2003	2004	2005	2006	2007
Mass consumption of BWW, total	t	359 318	436 611	440 333	719 357	626 715	698 663	678 832
including:								
Boiler No.9	t	142 290	131 360	158 093	186 365	153 206	192 763	189 830
Boiler No.14	t	-	-	-	215 999	263 572	287 278	271 974
Boiler No.15	t	101 194	122 560	114 575	130 230	23 877	11 122	-
Boiler No.16	t	115 834	182 691	167 665	186 763	186 060	217 500	217 028

Quantity of BWW supplied from the outside from 2001 till 2007 is given in Table D.2.2.

Table D.2.2. Quantity of BWW supplied from outside companies from 2001 till 2007

Parameter	Unit	2001	2002	2003	2004	2005	2006	2007
Quantity of BWW supplied to BPPM (for combustion) from outside companies	t	-	-	-	7 127	10 144	18 920	35 798

$BE_{WWS,dump,y}$ is the baseline emissions of CH₄ from decomposition of an additional quantity of WWS at the dump during the year y, t CO₂e;

The numerical value of $BE_{WWS,dump,y}$ is determined using the model “*Calculation of CO₂-equivalent emission reductions from biomass prevented from stockpiling or taken from stockpiles*” developed by “*BTG biomass technology group B.V.*” based on [R8].

$$BE_{WWS,dump,y} = (1 - w_{lignin,WWS}) \times k_{WWS} \times \frac{C_{WWS}^{db}}{100} \times a \times \zeta \times \left(1 - \frac{\varphi}{100}\right) \times (1 - \zeta_{OX}) \times \frac{V_m}{100} \times \rho_{CH_4} \times GWP_{CH_4} \times \sum_{x=2010}^{x=y} \left(WWS_{dump,BL,x}^{dry,add} \times e^{-k_{WWS}(y-x)} \right),$$

where $WWS_{dump,BL,x}^{dry,add}$ is the additional disposal of absolutely dry WWS at the dump under the baseline scenario as compared with the project scenario (amount of fresh biomass utilized) during the year x, t a.d.m.;

$$WWS_{dump,BL,x}^{dry,add} = FC_{WWS,PJ,x}^{dry},$$

where $FC_{WWS,PJ,x}^{dry}$ is the quantity of absolutely dry WWS fired under the project during the year x, t a.d.m.;

$$FC_{WWS,PJ,x}^{dry} = FC_{WWS,BH,PJ,x}^{dry},$$

where $FC_{WWS,BH,PJ,x}^{dry}$ is the absolutely dry WWS consumption in the boiler house under the project during the year x, t a.d.m.;

$$FC_{WWS,BH,PJ,x}^{dry} = FC_{WWS,BH,PJ,x}^m \times \frac{100 - W_{WWS,PJ,x}}{100},$$

where $FC_{WWS,BH,PJ,x}^m$ is the mass WWS consumption in the boiler house under the project during the year x, t;

$W_{WWS,PJ,x}$ is the average moisture content of WWS under the project in the year x, %.

$w_{lignin,WWS}$ is the lignin fraction of C for the WWS, it is assumed: $w_{lignin,WWS} = 0.25$ [R8, page 43];

k_{WWS} is the decomposition rate constant for the WWS, year⁻¹, it is assumed: $k_{WWS} = 0.185$ [R15, page 6];

C_{WWS}^{db} is the organic carbon content in the WWS on dry basis, %, it is assumed: $C_{WWS}^{db} = 41\%$ [R16].

It should be noted that calculation of methane emissions for each year y uses additional WWS stockpiling data from 2010 onwards.

D.3. Calculation of the GHG Leakages

The leakages are equal to zero [R1, Section B3].

D.4. Calculation of the project GHG emission reductions

The GHG emission reductions during the year y , t CO₂e:

$$ER_y = BE_y - PE_y$$

or

$$ER_y = ER_{CO_2,y} + ER_{CH_4,y},$$

where $ER_{CO_2,y}$ is the reduction of carbon dioxide emissions during the year y , t CO₂e.;

$$ER_{CO_2,y} = ER_{CO_2,RFO,y} + ER_{CO_2,lignite,y} + ER_{CO_2,grid,y},$$

where $ER_{CO_2,RFO,y}$ is the reduction of carbon dioxide emissions from combustion of residual fuel oil in the utilizing boilers during the year y , t CO₂e;

$$ER_{CO_2,RFO,y} = BE_{RFO,y} - PE_{RFO,y}.$$

$ER_{CO_2,lignite,y}$ is the reduction of carbon dioxide emissions from combustion of lignite in CHPP-6 boilers during the year y , t CO₂e;

$$ER_{CO_2,lignite,y} = BE_{lignite,y}.$$

$ER_{CO_2,grid,y}$ is the reduction of carbon dioxide emissions from combustion of fossil fuel at grid power plants during the year y , t CO₂e;

$$ER_{CO_2,grid,y} = BE_{grid,y}.$$

$ER_{CH_4,y}$ is the reduction of methane emissions during the year y , t CO₂e;

$$ER_{CH_4,y} = ER_{CH_4,BWW,dump,y} + ER_{CH_4,WWS,dump,y},$$

where $ER_{CH_4,BWW,dump,y}$ is the reduction of methane emissions from BWW decomposition at the dump during the year y , t CO₂e;

$$ER_{CH_4, BWW, dump, y} = BE_{BWW, dump, y} \cdot$$

$ER_{CH_4, WWS, dump, y}$ is the reduction of methane emissions from WWS decomposition at the dump during the year y, t CO₂e;

$$ER_{CH_4, WWS, dump, y} = BE_{WWS, dump, y} \cdot$$

The calculation method of GHG emission reductions was implemented in the computational model in the form of excel-file (Annex 4).

The calculation results are presented in the Table D.4.1.

Table D.4.1. Calculation of reduction of emissions GHG for 2008 and 2009

Parameter	Symbol	Unit	Value	
			2008	2009
Project emissions				
Project emissions	$PE_{NG,y}$	t CO ₂ e	34 693	33 017
Baseline emissions				
Baseline emissions	$BE_{NG,y}$	t CO ₂ e	188 872	163 048
GHG emission reductions				
GHG emission reductions	ER_y	t CO ₂ e	154 179	130 031

In accordance with the PDD, the projected GHG emission reductions amount to **193 792** t CO₂e for 2008.

In accordance with the PDD, the projected GHG emission reductions amount to **211 284** t CO₂e for 2009.

The factors that have led to GHG emission reductions level being lower than the level projected in the PDD are as follows:

1. Increase in residual fuel oil consumption by BWW-fired boilers against the level planned in the PDD by 1 161 GJ in 2008 and by 762 GJ in 2009 (Table D.4.2.). This has reduced GHG emission reductions level down to 190 269 and 209 437 tCO₂ in 2008 and 2009, respectively. In terms of percentage, the contribution of this factor in the total decrease in ERUs amount against the PDD level is estimated at 8.8 % for 2008 and 2.27 % for 2009.
2. Reduction of heat production by BWW-fired boilers against the PDD level by 224 670 GJ in 2008 and 540 428 GJ in 2009. This has further reduced ERUs amount to 173 491 and 168 834 tCO₂ for 2008 and 2009, respectively. In terms of percentage, the contribution of this factor in the total decrease in ERUs amount against the PDD level is estimated at 42.4 % for 2008 and 50.0 % for 2009.
3. Decrease in avoided disposal of BWW to dumps against the PDD level by 150 743 t in 2008 and 221 835 t in 2009. This has further reduced the ERUs amount to 162 527 and 142 232 tCO₂ for 2008 and 2009, respectively. In terms of percentage, the contribution of this factor in the total decrease in ERUs amount against the PDD level is estimated at 27.7 % for 2008 and 32.7 % for 2009.
4. Reduction of the heat supply factor against the PDD by 0.019 in 2008 and by 0.030 in 2009. This has further reduced the ERUs amount to 154 628 and 130 483 tCO₂ for 2008 and 2009, respectively. In terms of percentage, the contribution of this factor in the total decrease in ERUs amount against the PDD level is estimated at 19.9 % for 2008 and 14.5 % for 2009.
5. Reduction of electricity supply based on BWW-fired boilers operation against the PDD level by 795 MWh in 2008 and 811 MWh in 2009. This has further reduced the ERUs amount to 154 179 and 130 031 tCO₂ for 2008 and 2009, respectively. In terms of percentage, the contribution of this factor in the total decrease in ERUs amount against the PDD level is estimated at 1.1 % for 2008 and 0.6 % for 2009.

Table D.4.2. Factors causing decrease in GHG emission reductions against the PDD projections

Factor	2008		2009	
	PDD	MR	PDD	MR
Residual fuel oil consumption by BWW-fired boilers, GJ	10 021	11 182	10 021	10783
Heat production by BWW-fired boilers, GJ	4 119 597	3 894 927	4 119 597	3 579 169
Avoided disposal of BWW to dumps, t	303 681	152 938	303 681	81 846
Heat supply factor	0.696	0.677	0.696	0.666
Electricity supply based on BWW-fired boilers operation, MWh	1 968	1 173	1 968	1 157

CCGS LLC
27.04.2010



V. Dyachkov - Director of Project Implementation Department



Evgeniy Zhuravskiy, Specialist of Project Implementation Department

REFERENCES

- [R1] Project Design Document “Biomass wastes to energy at OJSC “Ilim Group” Branch in the town of Bratsk”. Ver.1.1/ 23.06.2009.
- [R2] Decision 9/CMP.1. Guidelines for the implementation of Article 6 of the Kyoto Protocol. FCCC/KP/CMP/2005/8/Add.2. 30 March 2006.
- [R3] Detailed design “Reconstruction of E-75-40K boiler No.16”. Moscow, 2000.
- [R4] Detailed design “Reconstruction of E-75-40K boiler No.14 with increase of steam output to 90 t/h, installation of fluidized bed furnace extension and replacement of ash collecting equipment at THPP of OJSC “Pulp and paperboard mill”. Moscow, 2002.
- [R5] Design “Installation of E-90-3.9-440DFT No.15 for fluidized bed combustion of wood wastes at THPP of OJSC “Ilim Group” Branch in the town of Bratsk”, Irkutsk, 2008.
- [R6] 2006 IPCC Guidelines for National Greenhouse Gas Inventories. Volume 2, Energy (<http://www.ipcc-nggip.iges.or.jp/public/2006gl/vol2.htm>).
- [R7] Operational Guidelines for Project Design Documents of Joint Implementation Projects. Vol.1. General Guidelines./ Version 2.3. Ministry of Economic Affairs of the Netherlands. May 2004. (<http://ji.unfccc.int/CritBasMon/CallForInputs/BaselineSettingMonitoring/ERUPT/index.html>).
- [R8] Methane and Nitrogen Oxide Emissions from Biomass Waste Stockpiles, PCFplus Research, World Bank, August 2002.
- [R9] RD 34.02.305-98 “The Methodology for Calculation of Gross Pollutant Emissions from TPP Boilers”. VTI. 1998.
- [R10] Reference book on heat engineering/Edited by V.N.Yurenev and P.D.Lebedev. In 2 volumes. Volume 2. M.: Energia, 1976.
- [R11] Methodology for determination of fuel, electricity and water requirements for production and transportation of heat and heat carriers in public heating systems. MDK 4-05.2004. Moscow, 2004.
- [R12] V.Y.Ryzhkin. Thermal power plants. – M.: Energoatomizdat, 1987.
- [R13] B.V.Sazanov, V.I.Sitas. Thermal energy systems of industrial enterprises. M.: Energoatomizdat, 1990.
- [R14] The Rules for Heat and Heat Carrier Metering. Central administrative board of the state power supervision. Moscow. 1995.
- [R15] Tool to determine methane emissions avoided from disposal of waste at a solid waste disposal site. UNFCCC.
- [R16] Feasibility study “Energy generating unit modernization” Stage III. Executive summary. Development of process flow diagrams and layout solutions. Irkutsk, 2006.

The provisions for quality control procedure in relation to preparation of project design documents and monitoring reports for greenhouse gas emission reduction projects at CCGS LLC



Approved by
Director General



M. Yulkin
December 8, 2009

REGULATIONS

on quality check and control of GHG emission reduction project design documents (PDD) and monitoring reports at CCGS LLC

1. GENERAL PROVISIONS

- 1.1. These regulations specify the quality control procedure for development of project design documents (PDDs) and monitoring reports for the projects aimed at GHG emission reduction from sources and/or increase of removal by sinks (hereinafter the “Projects”).
- 1.2. The quality control of PDDs and monitoring reports is carried out in conjunction with the structural subdivisions (departments) of CCGS LLC (hereinafter the “Company”) and the Project Owners (hereinafter the “Client”).
- 1.3. The quality control of PDDs and monitoring reports precedes their submission to an independent auditor for review.

2. QUALITY CONTROL OF PROJECT DESIGN DOCUMENTS

- 2.1. The PDD developed by a specialist of the Project Development Department shall undergo the following quality control procedure:
 - 2.1.1. The PDD shall be checked up by the Director of the Project Development Department or, on his instructions, by other specialist of the Project Development Department who was not directly involved in development of this PDD;
 - 2.1.2. Corrective actions shall be taken by the PDD developer and all corrections and amendments shall be agreed with the Director of the Project Development Department;
 - 2.1.3. The PDD shall be checked up by the Director of the Project Implementation Department or, on his instructions, by other specialist of the Project Implementation Department;
 - 2.1.4. Corrective actions shall be taken by the PDD developer and all corrections and amendments shall be agreed with the Director of the Project Implementation Department;

- 2.1.5. Final check-up and correction of the PDD shall be made by the Director of the Project Development Department;
- 2.1.6. The PDD shall be submitted to the Client for review;
- 2.1.7. Corrective actions shall be taken by the PDD developer and all corrections and amendments shall be agreed with the Client and the Director of the Project Development Department and if necessary with the Director of the Project Implementation Department;
- 2.1.8. The PDD shall be furnished to the Director General and the Client.
- 2.2. Upon completion of the above-described procedure and if there are no comments from the Director General and/or from the Client the PDD shall be deemed ready for determination by an independent auditor. Otherwise the procedure shall be repeated.
- 2.3. The Director of the Project Development Department shall check all sections of the PDD.
- 2.4. The Director of the Project Implementation Department shall check those sections of the PDD which describe the project monitoring plan and procedure. Other sections shall be checked by the Director of the Project Implementation Department if necessary or at his discretion.
- 2.5. The Director General shall take the final decision regarding submission of the PDD for determination to an independent auditor.

3. QUALITY CONTROL OF PROJECT MONITORING REPORTS

- 3.1. The project monitoring report prepared by a specialist of the Project Implementation Department shall undergo the following quality control procedure:
 - 3.1.1. The project monitoring report shall be checked up by the Director of the Project Implementation Department or, on his instructions, by other specialist of the Project Implementation Department who was not directly involved in preparation of this project monitoring report;
 - 3.1.2. Corrective actions shall be taken by the monitoring report developer and all corrections and amendments shall be agreed with the Director of the Project Implementation Department;
 - 3.1.3. The project monitoring report shall be checked up by the Director of the Project Development Department or, on his instructions, by other specialist of the Project Development Department;
 - 3.1.4. Corrective actions shall be taken by the monitoring report developer and all corrections and amendments shall be agreed with the Director of the Project Development Department;
 - 3.1.5. Final check-up and correction of the monitoring report shall be made by the Director of the Project Implementation Department;
 - 3.1.6. The monitoring report shall be submitted to the Client for review;
 - 3.1.7. Corrective actions shall be taken by the monitoring report developer and all corrections and amendments shall be agreed with the Client and the Director of the Project Implementation Department and, if necessary, with the Director of the Project Development Department;
 - 3.1.8. The monitoring report shall be submitted to the Director General and the Client.

3

- 3.2. Upon completion of the above-described procedure and if there are no comments from the Director General and/or from the Client the monitoring report shall be deemed ready for verification by an independent auditor. Otherwise the procedure shall be repeated.
- 3.3. The Director of the Project Implementation Department shall check all sections of the monitoring report.
- 3.4. The Director of the Project Development Department shall check those sections of the monitoring report which contain results of calculations of GHG emission reductions from sources and/or increase of GHG removals by sinks. Other sections shall be checked up by the Director of the Project Development Department if necessary or at his discretion.
- 3.5. The Director General shall take the final decision regarding submission of the monitoring report for verification to an independent auditor.

Basic steam supply diagram of OJSC “Ilim Group” Branch in the town of Bratsk

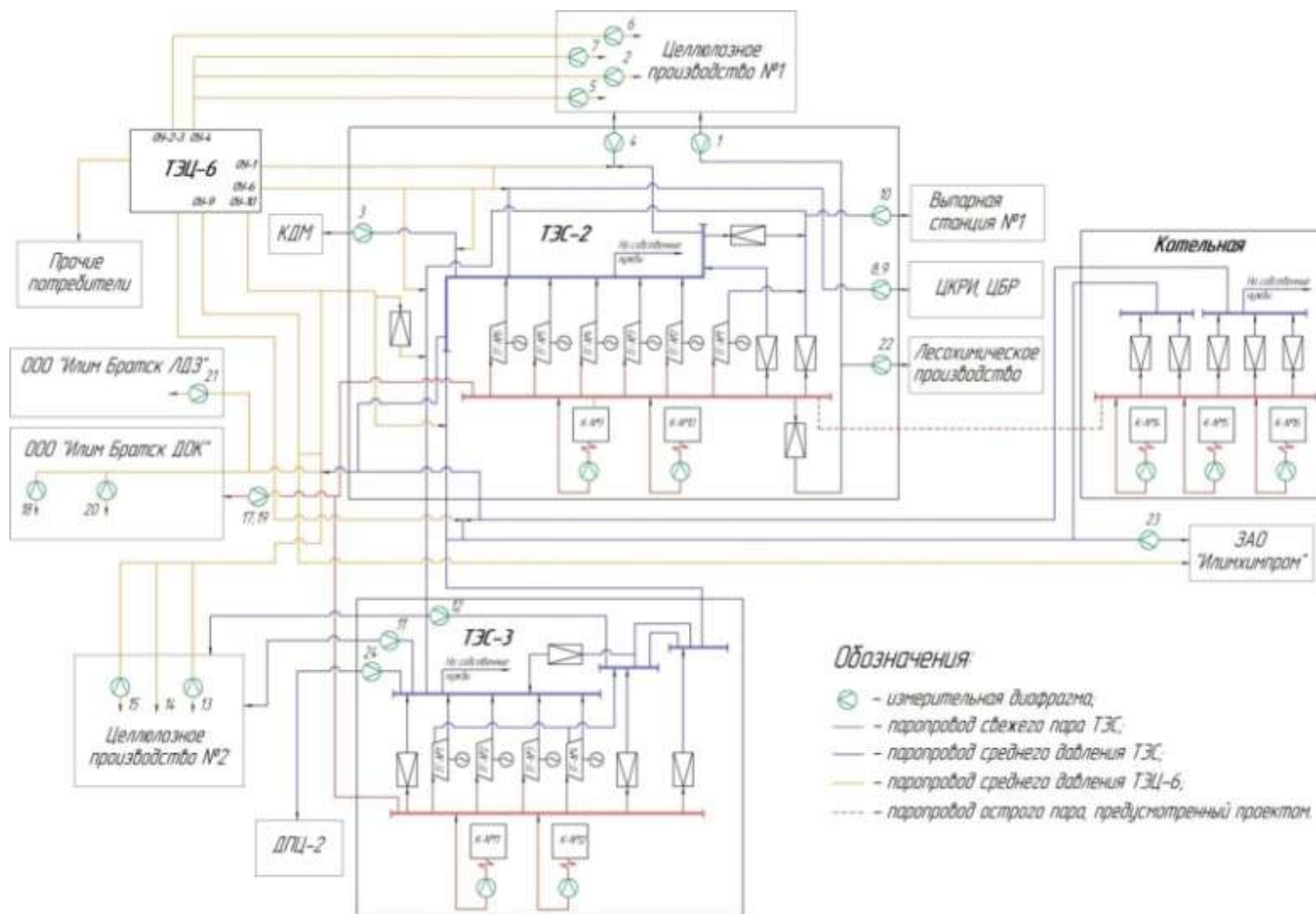

ANNEX 3

List of major heat consumers

№	Consumer	The source of steam
1	High yield cooking workshop	CHPP-2
2	High yield cooking workshop	Cooler Unit (CU)-4
3	Paperboard machine	CU-6, CHPP-2
4	Cooking workshop of cordage flow	CU-1, CHPP-2
5	Bleaching workshop of pulp production No.1	CU-4
6	Drying workshop of pulp production No.1	CU-2,3; CHPP-2
7	Flect	CU-4
8	Causticization and lime reburning workshop (CLRW)	CU-6, CHPP-2
9	Bleaching liquid workshop (BLW)	CU-6, CHPP-2
10	Evaporation workshop No.1	CHPP-2
11	Evaporation workshop No.2	CHPP-3
12	Cooking workshop of pulp production No.2	THPP
13	Cooking workshop of pulp production No.2	CU-10,12; THPP
14	Bleaching workshop of pulp production No.2	CU-10,12; THPP
15	Drying workshop of pulp production No.2	CU-10,12; THPP
16	Feed water to pulp production No.2	CHPP-3
17	Wood fiberboard production	THPP
18	Wood fiberboard production	CU-10,12; CHPP-2
19	Plywood production	CHPP-3
20	Plywood production	CU-10,12; CHPP-2
21	Timber factory	CU-10,12; CHPP-2
22	Wood chemical production	CHPP-2
23	Chlorine production	CU-9,10
24	Wood preparation workshop - 2	CHPP-3